

# Hopper Order Spec Sheet

Part # \_\_\_\_\_

LUG STYLES



STD



DROP

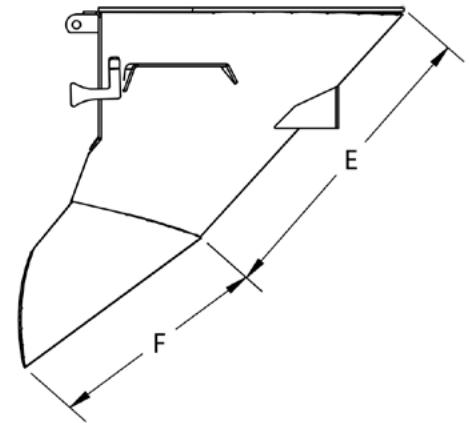
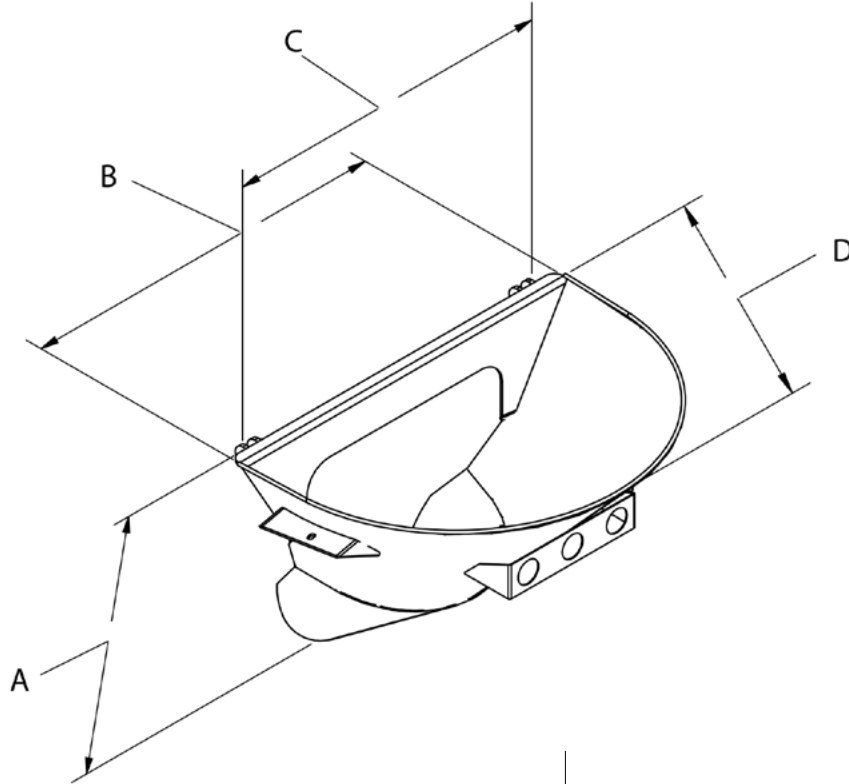

## Dimensions

A \_\_\_\_\_  
 B \_\_\_\_\_  
 C \_\_\_\_\_  
 D \_\_\_\_\_  
 E \_\_\_\_\_  
 F \_\_\_\_\_

Sales Person \_\_\_\_\_

Unit # \_\_\_\_\_

Customer Name \_\_\_\_\_

Street Address \_\_\_\_\_

City \_\_\_\_\_

State \_\_\_\_\_ Zip \_\_\_\_\_

Contact Person \_\_\_\_\_

**For Your Replacement  
Hopper Needs**

**Call 507-374-2239 or Fax 507-374-1094**

**www.ctmmixers.com**

**Con-Tech**  
 MANUFACTURING, INC.