

'Gun Rack' Tab Order Form

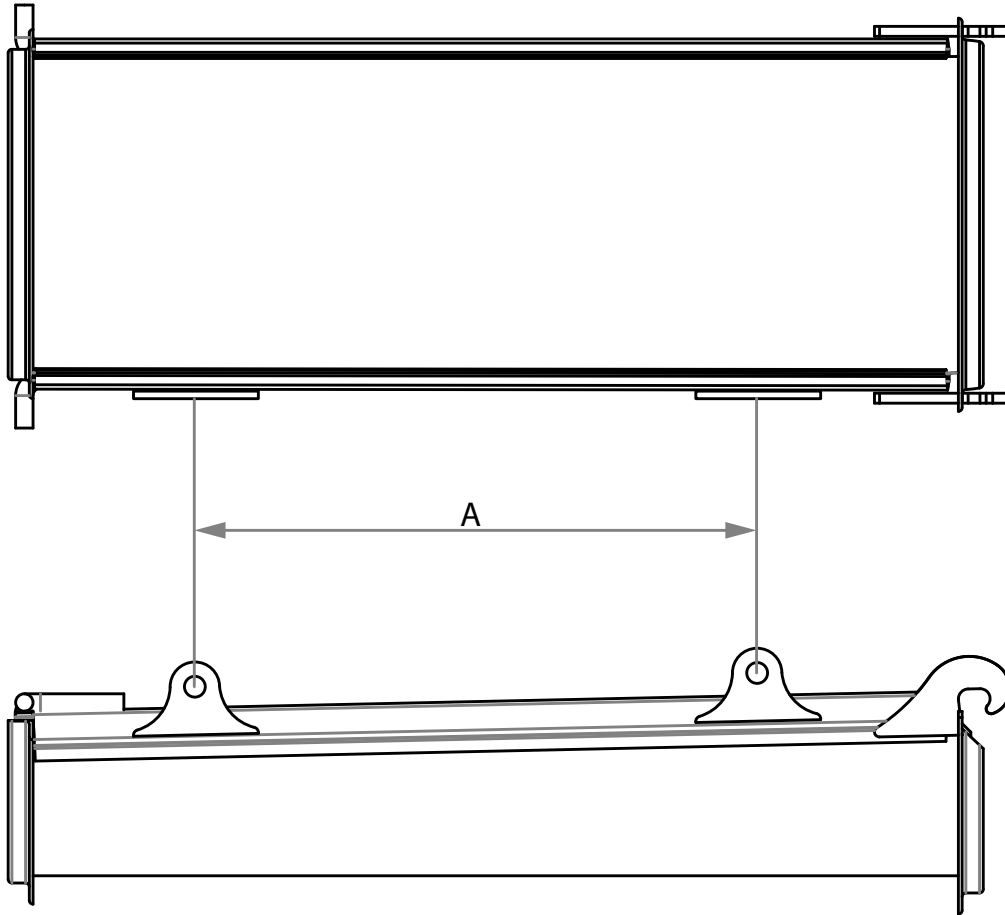

Part # _____

Qty: _____

Dimension:

A _____

Steel: Aluminum:

Special Instructions:

Sales Person _____

Unit # _____

Customer Name _____

Street Address _____

City _____

State _____ Zip _____

Contact Person _____

**For Your Replacement
Parts Needs**

Call 507-374-2239 or Fax 507-374-1094

www.ctmmixers.com

Con-Tech
MANUFACTURING, INC.